

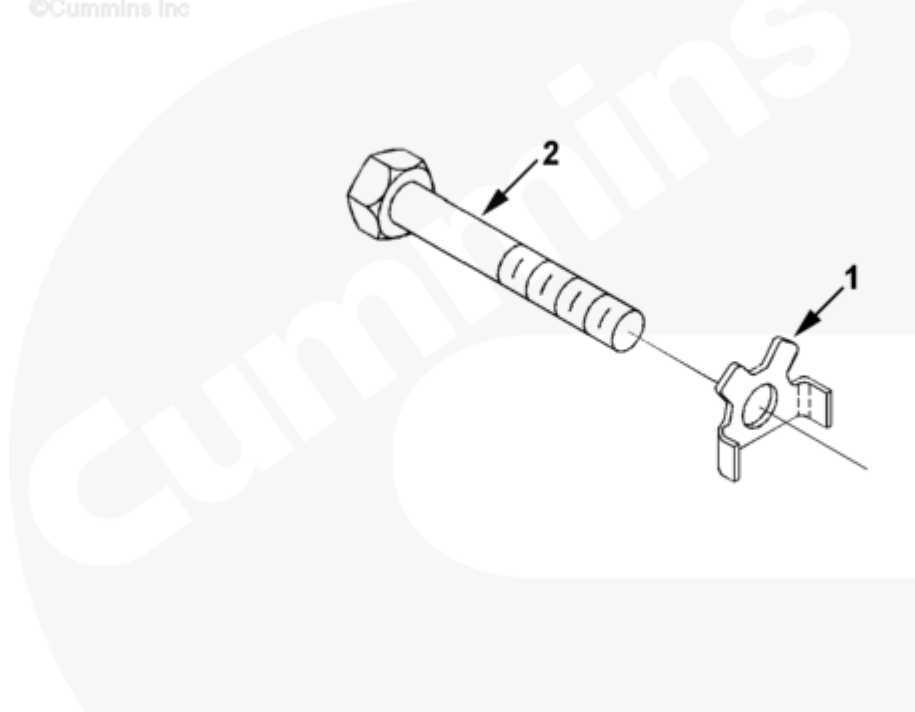

Parts Catalog - Option Detail

Electronic Parts Catalog - Option Detail				
Option	Group	Graphic	Film Card	Date
TB90063	99.01	tb942gv	Z	11-JUN-08
Engines	6C8.3, C GAS PLUS CM556, G8.3, G8.3 CM558, GTA8.3 CM558, ISC CM2150, ISC CM554, ISC CM850, ISC8.3 CM2250, ISC8.3 G CM2180 C101, ISL CM2150, ISL CM554, ISL CM850, ISL G CM2180, ISL8.9 CM2150 L110, ISL8.9 CM2880 L112, ISL9 CM2150 SN, ISL9 CM2250, ISL9 CM2350 L101, ISL9 CM2350 L111, ISLE4 CM850, L GAS PLUS CM556, L8.9, L8.9 L121, L8.9G CMOH2.0 L125B, L9 CM2350 L116B, L9 CM2350 L119B, L9 CM2350 L120C, L9 CM2350 L123B, L9.3 L105, L9.5 L117, L9N CM2380 L124B, QSC8.3 CM2250, QSC8.3 CM2880 C102, QSC8.3 CM554, QSC8.3 CM850(CM2850), QSL9 CM2250, QSL9 CM2250 L115, QSL9 CM2350 L102, QSL9 CM2350 L107, QSL9 CM2350 L118, QSL9 CM2350 L122, QSL9 CM554, QSL9 CM850(CM2850), QSL9 G CM558, QSL9 M CM2250 L106, QSL9.3 CM2880 L113			

©Cummins Inc



tb942gv

[SMALL](#) | [MEDIUM](#) | [LARGE](#)

Cart	Ref No	Part Number	Part Description	Required	Remarks
View My Cart					
		TB90063	Turbocharger Arrangement		MR - ARRANGEMENT, TURBO...(More)
					Engine Family: C Series
					Cylinders: 6
					Exhaust Outlet Location:
					HMFO
					Turbo Exhaust Location from

					Front Face of Block
					(mm): 417.3
					Exhaust Vertical from Crank
					Centerline (mm): 603.2
					Exhaust Horizontal from Crank
					Centerline (mm): 254.7
					Aspiration: Charged Air
					Cooled
					Oil Supply Routing: Outboard
					Intake Cover Provided: No
					Turbine Outlet Flange Type:
					Full Marmon
					Manifold Type: Dry
					Turbocharger Type:
					Non-Wastegate
					Structure Code: 02 EBM
					Engine Design Phase: Current
					Product
					Cylinder Head Type: Standard
					Requires Air Heater/Spacer:
					No
					Compressor Outlet Flange
					Type: Half Marmon
					Compressor Outlet Diameter
					(mm): 74 (2.91 in.)
					Compressor Outlet Fixed
					Location (CCW)(deg): 60
					Mounting Studs Provided: 0
					Additional Mounting Bosses:

					6
					Turbo Drain Location: Front
					Drain
					Bearing Housing Manufacturer:
					Holset
					CPR Angle (deg): 240
					Turbine Angle (deg): 0
					Turbo Drain Tube Type:
					Flexible
					Exhaust Support Flange:
					2 -
					Turbo Model: H1E
					Alternator Support Provision:
					No
					HP Limitation (
					Manifold Style: 1 Piece
					Base Turbo ID17/15 Number:
					3535749
					Bearing Housing Cooling
					Provision: Oil Cooled
<input type="checkbox"/>	1	3914708	Lock Plate	12	
<input type="checkbox"/>	2	3929537	Hexagon Head Cap Screw	12	M10 x 1.50 x 70